

110 Series

LED Architectural Wall / Ceiling Mount

Type:

Catalog Number:

Project/Location:

Approved By:

SPECIFICATIONS

Housing: Heavy-duty construction of corrosion resistant die cast aluminum.

Gasket: Closed cell silicone foam gasket. Seals out moisture, dust and insects for weather-tight operation.

Mounting: Surface wall or ceiling mount over standard J-box.

Lens: One piece molded white opal, impact resistant 1/8" thick UV stabilized polycarbonate lens.

Driver: Constant current and Universal input voltage 120-277V, 50-60Hz line voltage frequency. Operating temperature -20°C to 40°C, Power Factor $\geq .90$.

LED: Specify amber (A), blue (B), green (G), red (R), or 3000 (30K), 3500 (35K), 4000 (40K), and 5000K (50K). 40K Standard.

Lumens: 1530.

Finish/Colors: Zinc based primer with polyester powder coat finish in Matte Black (MB), Matte White (MW), Matte Bronze (BZ), Silver Gray (SG), or a custom color (CC).

Testing: LM79, LM80, ETL.

Conforms to UL Standard 1598. Suitable for wet locations.

See options page for additional information or consult factory.

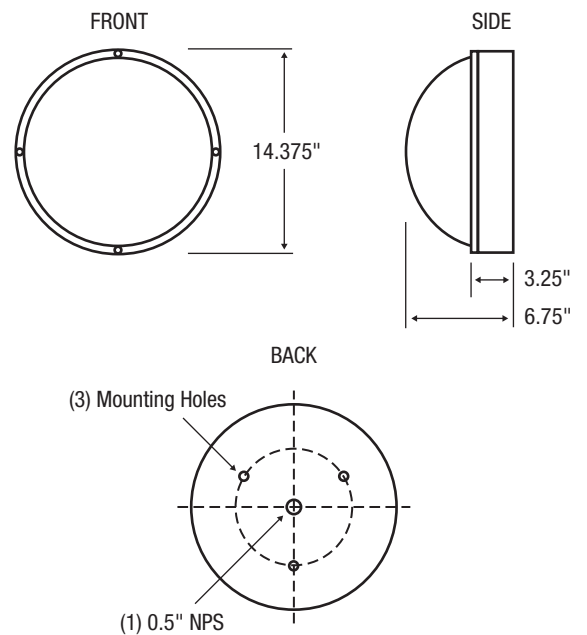

Series	Source	Max Wattage
110	LED	21W

ORDERING EXAMPLE

110 - A - 21WLED - 40K - 120 - MB

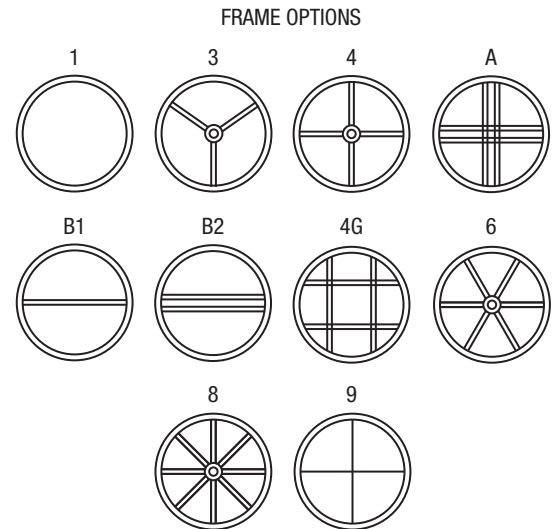

ELCAST LIGHTING

815 S. Kay Ave., Addison, IL 60101 USA • 630.543.5390
www.ElcastLtg.com • ElcastLtg@ElcastLtg.com

Made in USA – 5 year limited warranty

©2017. Specifications are subject to change without notice. Consult factory for verification.